

# Ni-Hard Series Submersible Slurry Pumps

*Versatile, really robust and definitely reliable*



*We move SOLIDS*

**MBH<sup>®</sup>**  
**PUMPS**

# Waste Water Handling is simple fo us

## The Ni-HARD series submersible slurry pumps for rugged usage

Slurry revival is an essential part of day-to-day operations in a wide range of industries, such as mining, ore dressing, sand contracting, ash handling and steel milling. The applications in these industries make heavy demands on slurry pumps, particularly in terms of the cost incurred when it comes to wear and tear, repairs and maintenance. In Ni-HARD series of pumps the wet end, indeed all wear parts, are made of Ni-HARD which provides complete wear protection.

## Higher pump efficiency over time

State-of-the-art technology makes MBH Ni-HARD series pumps extremely efficient & highly dependable. Innovative features such as the unique adjusting Impeller clearance system provides low cost of ownership.

## Less downtime

The excellent Solid handling capability of our channel-impeller pumps guarantees maximum operating time and substantial reductions in maintenance costs caused by pump jamming or clogging.

## Lifelong reliability

The NI-HARD series pumps are designed for continuous pumping under the most difficult operating conditions. The well-proven design is based on our long experience in the waste water and slurry related industries.



## Why Submersible ?

The submersible concept offers numerous benefits over dry-mounted pumps. As it doesn't require any support superstructure, it requires less space for operation and is very easy to install. Being submersible means its flood-proof. Operating underwater also means quiet operation. On top of that, the time for maintenance can be greatly reduced.

The Ni-Hard Series Submersible pumps are made to operate over the complete pump curve, not just one specific duty point. This means that the pump can be used in numerous applications within its range, instead of being "one pump-one application".



# Ni-Hard Series Submersible Slurry Pumps

## Installations

**Utkal Alumina Rayagada (Aluminium Smelter)**  
60 HP Submersible slurry pumps (2 units)

**NTPC Vindhyachal (Power Plant)**  
40 HP submersible slurry pump (2 units)

**Sterlite Copper (Copper Smelter)**  
75 HP submersible slurry pump (1 unit)

**JSW Energy (Baspa Stage II Hydroelectric Power Station)**  
40 HP submersible slurry pump (1 unit)

**Sembcorp (2640 MW Thermal Power Complex)**  
40 HP submersible slurry pump (1 unit)

**Sterlile Copper (Copper smelter plant)**  
40 HP submersible slurry pump (1 unit)  
10 HP submersible slurry pump (1 unit)

**NTPC Singrauli (Thermal Power)**  
85 HP submersible slurry pump (2 units)

**Tata Sukinda (Steel Mines)**  
10 HP submersible slurry pump (1 unit)

**Udupi Power Corporation Ltd.**  
(Thermal power - seawater intake)  
120 HP submersible slurry pump (1 unit)

**Krishnapatnam - BGR Energy Ltd. (Contractor)**  
(Desalination Plant)  
40 HP submersible slurry pump (4 units)





1



2



3



4



5



6



7



8

## Applications

- 1. **Coal mines and washery**
- 2. **Steel plant**  
Steel continuous casting & hot rolling mills;  
Slag granulation; Beneficiation plant; SMS
- 3. **Power**  
Coal Handling plant; Ash handling plant;  
Balance of plant
- 4. **River cleaning**  
Dredging
- 5. **Minerals processing**  
Smelters
- 6. **Hydro power**  
Turbine sumps; Sump cleaning
- 7. **Mining**  
Coal; Manganese; Zinc; Iron Ore; Nickel;  
Gold; Gypsum; Silica
- 8. **Tunneling and construction**  
Dewatering and piling

# Ni-Hard Series Submersible Slurry Pumps

## GA Drawing

All Dimension are in mm

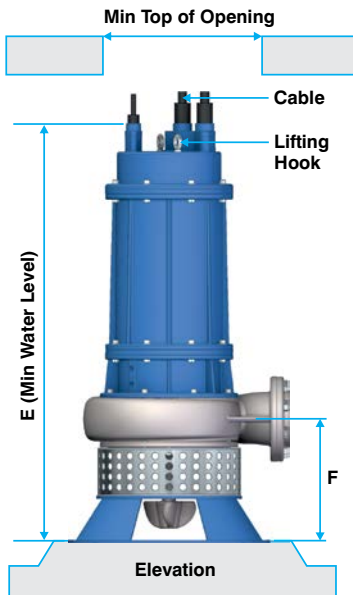

Model	Min. Opening	A	B	C	D	E	F	Weight in kg
4NSS10S4A	801	282	219	438	100	1037	260	198
4NSS15S4A	801	282	219	438	100	1102	260	216
4NSS20S4A	801	282	219	437	100	1167	265	275
4NSS30S4A	801	282	219	437	100	1312	265	320
4NSS40S4B	885	333	252	500	100	1432	375	480
4NSS40S4C	885	333	252	500	100	1432	375	480
4NSS50S6A	893	333	260	518	150	1442	380	495
4NSS60S6A	893	333	260	518	150	1502	380	664
4NSS85S6A	881	330	251	498	150	1609	395	784
6NSS120S6B	1067	468	319	635	200	1850	270	1233
6NSS120S6C	1067	468	319	635	200	1850	270	1233
6NSS150S8B	1067	468	319	635	200	1950	270	1320
6NSS150S8C	1067	468	319	635	200	1950	270	1320

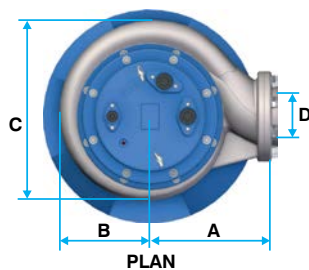

**100 mm PUMP**  
(DIN-24255-733)

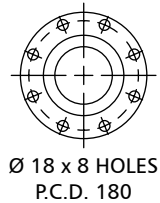

**150 mm PUMP**  
(DIN-24255-733)



**200 mm PUMP**  
(DIN-24255-733)

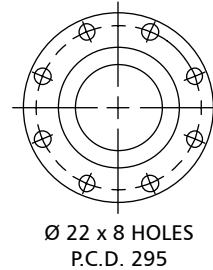

## Specifications

MODEL	4NSS10S4A Handy	4NSS15S4A Junior	4NSS20S4A Maximo	4NSS30S4A Maximo XL	4NSS40S4B Terminator H	4NSS40S4C Terminator HH
Power	10.0 / 7.5	15.0 / 11.0	20.0 / 15.0	30.0 / 22.0	40.0 / 30.0	40.0 / 30.0
Speed	1450	1450	1450	1450	1450	1450
Max solid content	65%	65%	65%	65%	65%	25%
Max specific gravity kg/L	2.8	2.8	2.8	2.8	2.8	1.5
Max partical size	32 mm	32 mm	32 mm	32 mm	32 mm	12 mm
Max slurry temperature	90 c	90 c	90 c	90 c	90 c	90 c
Max flow m <sup>3</sup> /hr - Q max	105 m <sup>3</sup> /hr	130 m <sup>3</sup> /hr	150 m <sup>3</sup> /hr	140 m <sup>3</sup> /hr	220 m <sup>3</sup> /hr	160 m <sup>3</sup> /hr
Max head meter - H max	18 mtr	23 mtr	24 mtr	33 mtr	38 mtr	60 mtr
Max efficiency Duty point	60%	60%	61%	57%	62%	51%
Max submergence depth	28 mtr	28 mtr	28 mtr	28 mtr	28 mtr	28 mtr
Recommended pH range	4 - 10	4 - 10	4 - 10	4 - 10	4 - 10	4 - 10

## Performance Curves 50 Hz

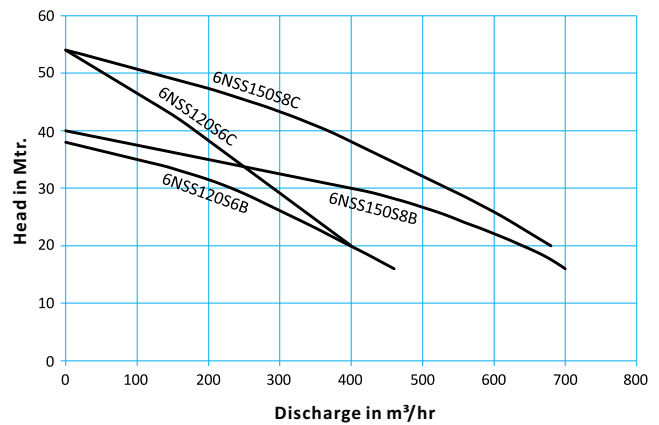
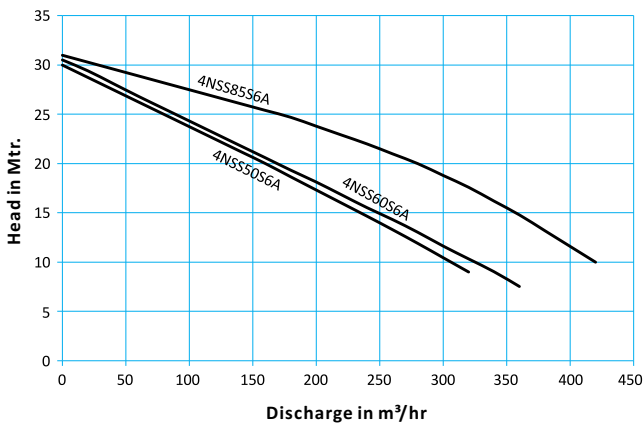
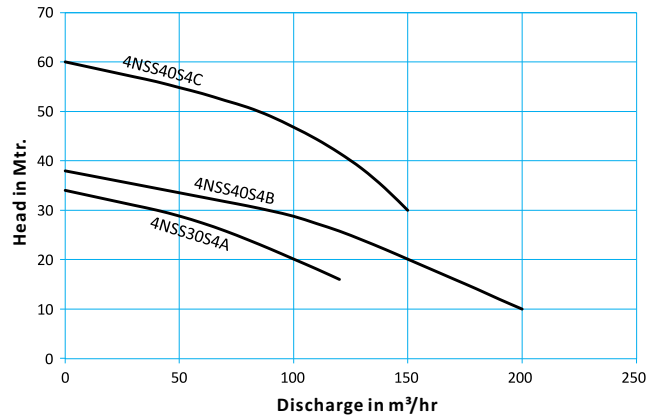
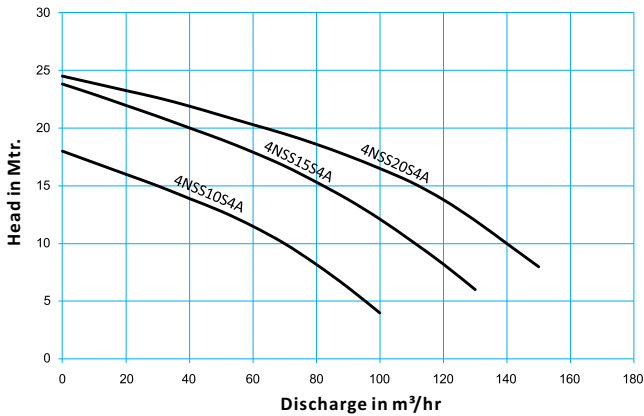

4NSS50S6A Commando	4NSS60S6A Destroyer	4NSS85S6A Finisher	6NSS120S6B Excavator M	6NSS120S6C Excavator H	6NSS150S8B Ultimate M	6NSS150S8C Ultimate H
50.0 / 37.0	60.0 / 45.0	85.0 / 63.5	120.0 / 90.0	120.0 / 90.0	150.0 / 112.0	150.0 / 112.0
1450	1450	1450	960	960	960	960
65%	65%	65%	65%	40%	65%	40%
2.8	2.8	2.8	2.1	1.5	2.1	1.5
38 mm	38 mm	38 mm	45 mm	30 mm	76 mm	40 mm
90 c	90 c	90 c	90 c	90 c	90 c	90 c
310 m³/hr	360 m³/hr	430 m³/hr	500 m³/hr	460 m³/hr	800 m³/hr	800 m³/hr
30 mtr	30 mtr	30 mtr	38 mtr	53 mtr	40 mtr	53 mtr
55%	52%	58%	59%	51%	62%	52%
28 mtr	28 mtr	28 mtr	28 mtr	28 mtr	28 mtr	28 mtr
4 - 10	4 - 10	4 - 10	4 - 10	4 - 10	4 - 10	4 - 10

Extensive Range of MBH wastewater pumps now comes with Optimal cooling solution for various pumping applications. This comprehensive selection of pump options will provide optimal performance and power, while reducing operating costs and simplifying maintenance.

Cooling is a key aspect of submersible pump performance. MBH offers several types of cooling systems, including advanced closed loop cooling, which delivers the ultimate flexibility and reliability.

## Closed-loop cooling system with glycol cooling

MBH closed loop cooling system uses the latest technology to secure industry leading performance. It is suited to all DRY-INSTALLATIONS, as well as wet installations where the motor is not sufficiently submerged. Coolant is circulated between the inner and outer cooling jacket, down to the cooling bottom. The main strength of closed-loop cooling is that it is not sensitive to impurities in the pumped media. The close loop ensures the coolant is never contaminated. The Heat from stator body is transferred to the coolant, and the coolant at the same time is pumped at high speed inside the jacket with the help of specially designed 3D printed Impeller.

The coolant in the closed loop system is a precise mixture of pure distilled water and a special glycol formulation. It has excellent heat transfer and corrosion resistance properties and is freeze-proof upto -45 C.

Now ask for Closed loop jacketed submersible pumps for all variety of MBH submersible waste water pumps as an option.



<p><b>NS Series</b> Submersible Sewage Pumps</p>	<p><b>Ni-HARD Series</b> Submersible Slurry Pumps</p>	<p><b>CP Series</b> Submersible Contractor Pumps</p>
<p>Technical Specifications :</p> <p>Head : upto 65 meters</p> <p>Capacity : upto 3000 m<sup>3</sup>/hr</p> <p>HP : 10 to 300</p> <p>Solid Size : upto 150 mm</p> <p>Frequency : 50 / 60 Hz</p>	<p>Technical Specifications :</p> <p>Head : upto 60 meters</p> <p>Capacity : upto 800 m<sup>3</sup>/hr</p> <p>Solid content by weight : 65%</p> <p>Specific gravity : 2.8 kg/l</p> <p>Particle size : 40 mm</p> <p>Frequency : 50 / 60 Hz</p>	<p>Technical Specifications :</p> <p>Head : upto 50 meters</p> <p>Capacity : upto 450 m<sup>3</sup>/hr</p> <p>HP : upto 60</p> <p>Solid Size : 40 mm</p> <p>Frequency : 50 / 60 Hz</p>
<p><b>* No need of external water source for cooling. * Can use a submersible pump as a surface pump.</b></p>		



# Ni-Hard Series Submersible Slurry Pumps

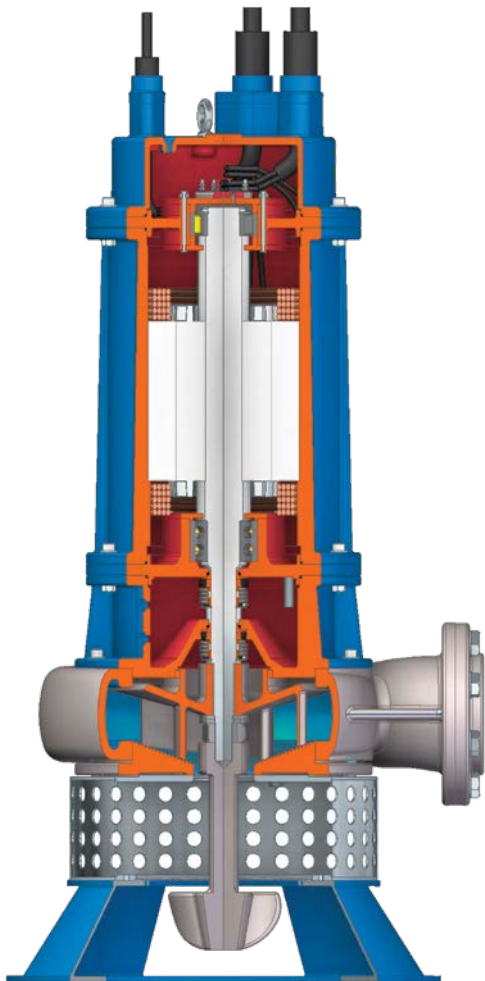

## Design

### Bearings

The bearing arrangements with double angular contact ball bearings with deep groove ball bearings give the best resistance to the radial and axial thrust load combination & generously oversized to give extended life when pumping high specific gravity slurries.

### Moisture Detection Probe

The moisture detector indicates any moisture penetration into the motor.

### Thermal Motor Protection

Built-in temperature sensors enable tripping of the motor if the temperature rises above 110 deg. C and restarts at 90 deg. C, giving complete dry run protection.

### Double Mechanical Seals

All "MBH" pumps have as standard equipment double mechanical seals which seal off the motor from the pump section. The seal has seal faces made from silicon carbide for long life. The design of the oil chamber ensures efficient cooling of the seals.

### Shaft with Rotor

Rotor is designed with two cage such that it take care of starting torque to handle thick slurry and A shaft with a die-cast rotor on the motor side and a shaft protection sleeve on the pump side, ensures better life for the shaft. The compact seal arrangement has minimised shaft over-hang and consequently minimises shaft deflection.

### Wet Parts

Wet parts like volute, impeller & agitator are of Ni-hard or SS 316 depend on slurry to be handled & impeller is open type such that there is no chance to block the pump.

### Cable

The cable has a special triple protection with waterproof insulation as such is much more resistant against damage. The IP68 rated cable gland seals against both the inner and outer sheathes. It is almost impossible for water to ingress to the electrical connections.

## Accessories



### Hose

MBH recommends all its submersible slurry pumps are suspended on chains, followed by a length of reinforced flexible slurry hose pipe, before connecting to any rigid pipe. This enables the pump to operate correctly when it is in thick heavy slurries, as when the pump is started and slurry has settled around it there is chance of vibrations. As the pump is suspended on chains, the vibration doesn't harm the pump and the surrounding structure, allowing standing water to get to the impeller.

MBH hoses are supplied with PN 16 flanges on both ends as standard.



### Lifting Chain (with Shackles)

Custom made lifting chains are recommended so the slurry pump is lifted from a single point. This means that the pump remains vertical at all times, and is not lifted on an angle, which can happen on site if only one of the lifting points is used. Additionally when starting the pump when it is submerged in settled slurry it allows the pump to vibrate as described above.

As it is a submersible pump the shackles and chain unit come in a galvanised finish to minimise corrosion and maximise working life.

The chain unit is supplied with two shackles to couple it directly to the Pump.

### Control Panel

We at MBH, understand the Investment a customer is making in buying our Submersible Ni-Hard series pumps and for getting optimum output of your investment, we recommend you to opt for our Control Max series Control panels.

The MBH fully automatic control panel has Two main modes of operation.

#### 1. Manual mode

The operation can start Stop the pump as required.

#### 2. Automatic with level control switches or Float switch

When the high level Sensor is activated, the pump will start.

When the low current relay senses the drop in power the pump will stop.

In option to these we can also offer Fully automated PLC based Control panels with Timer Start Features.

#### All MBH panels Protect against :

- Earth leakage faults - damage to the cable or pump
- current overload of the pump
- Phase imbalance - voltage variation of the incoming supply phases
- phase rotation - to ensure the pump runs in the correct direction
- phase loss- the loss of one or more of the incoming phases
- under voltage - if the incoming voltage is too low
- over voltage - if the incoming voltage is too high



# Ni-Hard Series Submersible Slurry Pumps

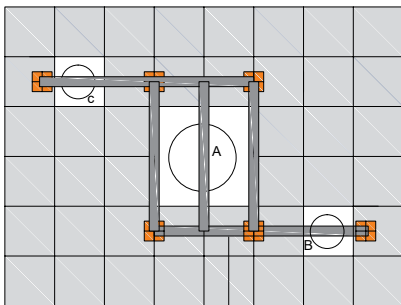

A Slurry Pump  
 B Dewatering Pump  
 C Jetting Pump

Chain Pulley Attachment

PLAN

## Pontoon Slurry Sucker

The Slurry Sucker units incorporate pumps from MBH DC series and Ni-HARD Series, which are used for dewatering and slurry applications. Selection of the pump will be determined by the type of the operation and could include either dewatering pumps, where agitation of the slurry is required, or Ni-hard slurry pumps where there is a need to remove slurry from Ash ponds in power plants or dredging at the Shore.

*\* Can be Fully customized for your project requirements*

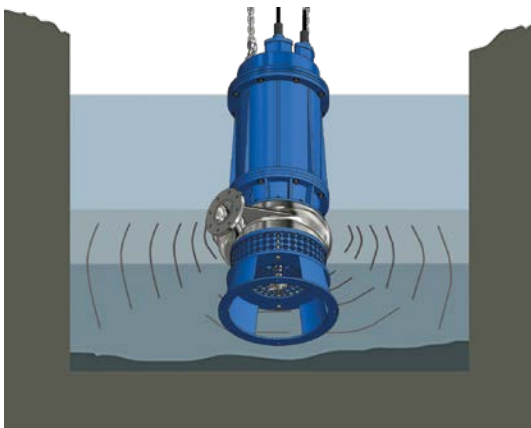

## Agitator Details

MBH Ni-hard slurry pump is fitted with agitator which eliminates solids accumulating on the sump floor and can significantly reduce maintenance costs resulting from digging out sumps and downtime due to solids building up and choking off the suction of conventional pumps. It is because of MBH Agitator blade that the highest efficiency in material mixing can be achieved.



Heavy duty blades situated in front of the pump's suction agitates, chops, cuts shreds incoming solids such as metal, plastic, wood, solid waste prior to them entering the impeller. The Agitator eliminates the pump and system from getting clogged.

## Best Operating Practice

To ensure that you get the best performance from your MBH Submersible Slurry Pump, we recommend that you follow the best practice procedures laid out on this page.

## Correct Installation Example

- A good water to slurry ratio
- Sump level control - If the sump empties, the pump should switch itself off via the automatic control panel. The pump will switch on via a float switch or timer when the level rises
- Pump should not exceed 20 starts per hour
- The pump should be suspended by chains at least 200 mm from base of the sump to ensure maximum concentration of solids pumped

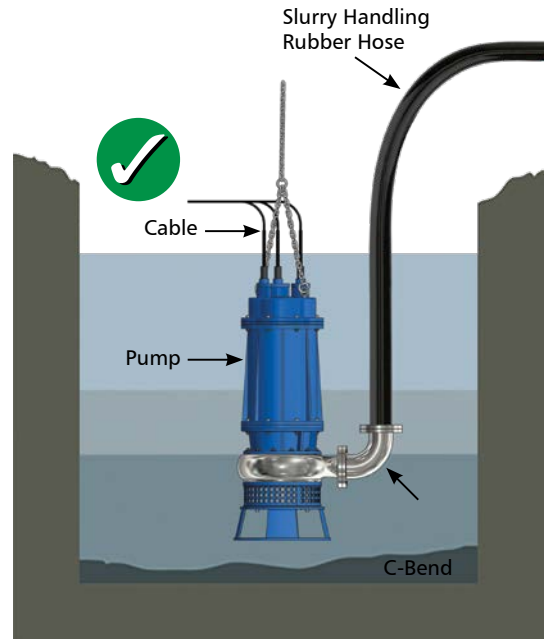

## Power Supply & Servicing

Always ensure that the pump is correctly connected and protected by using the MBH Fully Automatic Control System which has Earth Fault Leakage Protection.

The pump should be inspected as per the recommendations in the operating and maintenance manual.

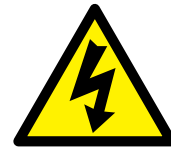

## Incorrect Installation Examples

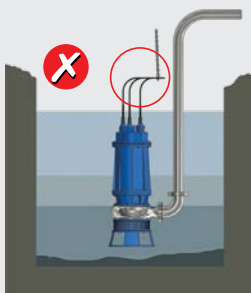

**Correct Lifting**  
When moving or suspending the pump, always use certified lifting equipment. Never lift or suspend the pump using the power cable.

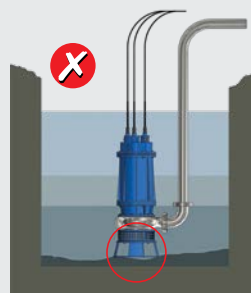

**Pump Positioning**  
When pumping heavy slurries, always suspend the pump with the certified lifting equipment 200 mm minimum above the bottom of the sump. Do not let the pump sit on the bottom of the sump.

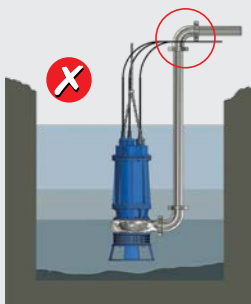

**Heavy Duty Flexible Hose Usage**  
When pumping heavy slurries, always suspend the pump with the certified lifting equipment 200 mm minimum above the bottom of the sump. Do not connect the pump directly to a rigid pipe.



**Vertical Positioning**  
For the best operation of the pump and inducer, ensure that the pump is suspended in a vertical position.

Inquire about our other product range for  
Dewatering Pumps



DCAL Series  
Dewatering Pumps



DS Series Duplex Steel  
Submersible Pumps



Submersible  
Portable Pumps



Pro-Prime Series  
Autoprime Pumps

*Specifications and performance are subject to change without prior notice.  
Images used are for illustration purpose only.*



mbh pumps (gujarat) pvt. ltd.  
Plot No. 14, G.I.D.C. Indl. Estate,  
Naroda, Ahmedabad - 382 330, India.  
+91-79-2282 3066, 2282 1018  
marketing@mbhpumps.com  
exports@mbhpumps.com  
www.mbhumps.com

